

## Installation and Operating Instructions **CE**

0093.032.00 c

### Lumistar Luminaire Crescent Design ME 65, ME 80, ME 100, ME 125, Stainless Steel

For applications with a combined sight and light port.  
Suitable for circular screw-type sight glass fittings according to DIN 11851 or similar.

• **Important, please note:**

If it is intended to retrofit the Lumistar Luminaire Crescent Design ME to an already existing screwed sight glass fitting, the slotted cover nut should be ordered as well; otherwise the existing one will need to be adapted accordingly (see bore diameter 'd 8' referred to in DIN 11851).

• **Mechanical installation:**

- **Caution:** Do not look into light – danger of impaired eyesight!
- Loosen the slotted cover nut on the screwed sight glass fitting.
- Pass the slotted cover nut over the connecting cable and luminaire housing.
- Make sure that the sight glass disk is correctly seated in the fitting.
- Focus the luminaire by aligning the centring feature on the bead and the opening in the slotted cover nut (see drawing).
- Screw the slotted cover nut onto the weld-on neck with the luminaire in position.

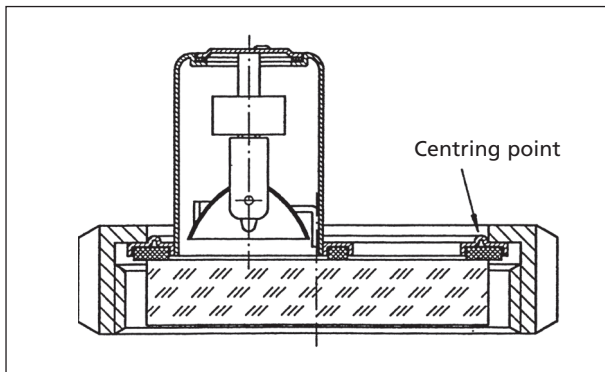

• **Caution:**

Do not establish the electrical connections until the mechanical installation has been completed!

• **Electrical connection:**

- Lumistar Luminaires Crescent Design ME are works-fitted with a 3 m cable tail (Lapptherm 105, up to 90°C/194°F).
- The cable is firmly connected to the luminaire by way of the cable gland.
- The cable is already terminated to the internal wiring in the luminaire and is supplied ready for use.



Lumistar luminaire crescent design ME

• **Fitting a new or different connecting cable:**

- Select a connecting cable which is suitable for the operating conditions.
- The diameter of the cable should be the same as that of the cable gland.
- Remove the reflector.
- Insulate the cable ends.
- Insert the cable through the cable gland into the lamp chamber and wire to the terminals or push-on blades (leading the protective earth along the housing wall).
- Tighten the cable gland.
- Re-install the reflector.
- It is easier to carry out the connection process if the filament lamp is first removed. The user then has more space, and damage to the lamp is prevented.

• **Changing the lamp:**

- **Caution!** Before opening the luminaire, check that it is not too hot!
- Disconnect the luminaire from the power supply
- Tip: By loosening the cable gland slightly it is easier to work on the luminaire as the internal wiring then has more space. Tighten again once the lamp has been replaced!
- Open the cover and pull it out together with the installed lamp holder and the defective filament lamp.
- Remove the defective lamp.
- Using a protective cloth to hold the new filament lamp, insert it carefully into the 2-pin socket and push it into place.
- Replace the cover with lamp holder and new filament lamp, check that the cables are in the correct position before screwing on the cover.
- Tighten the cable gland once the lamp has been replaced.
- Reconnect the power supply.